

SKF TMMS

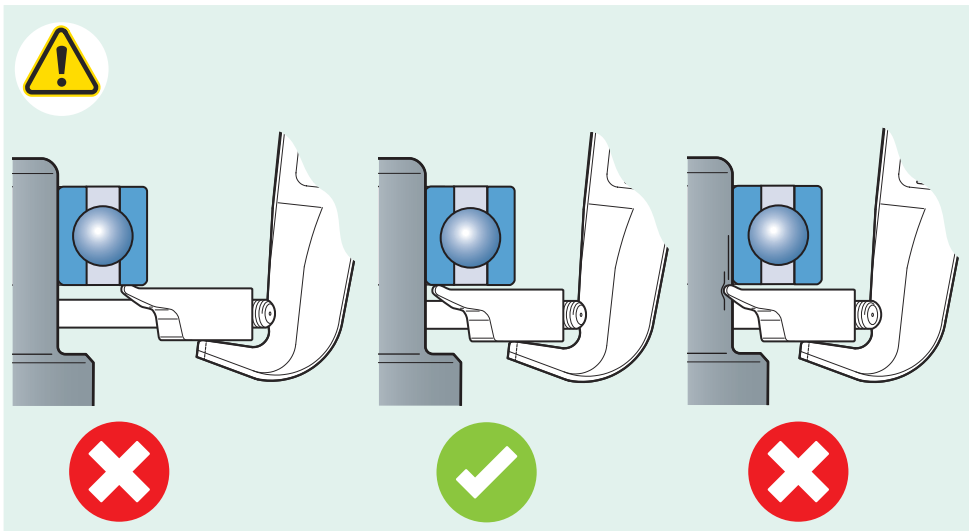

Instructions for use
Bedienungsanleitung
Instrucciones de uso
Mode d'emploi

Manuale d'istruzioni
Instruções de uso
Инструкция по эксплуатации
使用说明书

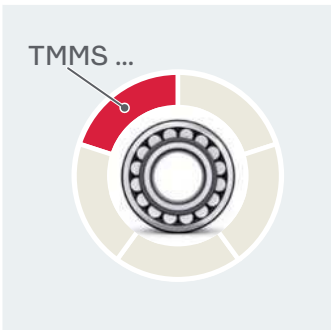
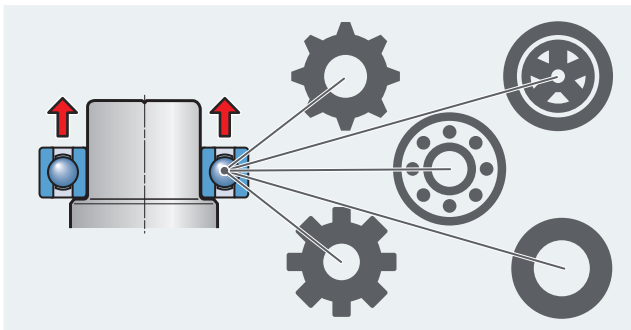
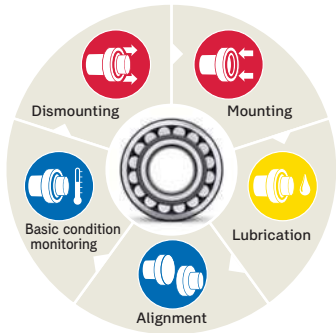

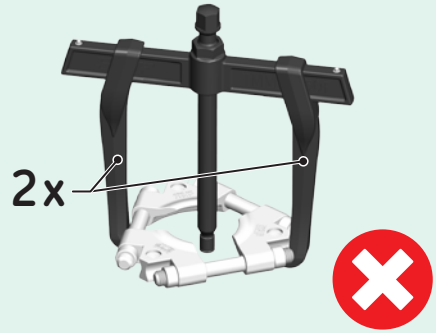

TMMS ...

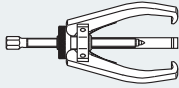
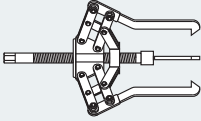
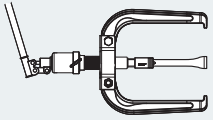
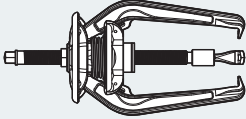
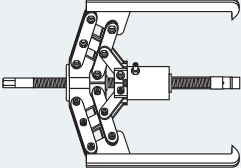
| | | 50 | 100 | 160 | 260 | 380 |
|-------------------------------------------------------------------------------------|------------|----|-----|-----|-----|-----|
|  | 3x185 | ✓ | ✗ | ✗ | ✗ | ✗ |
| | TMMP 3x230 | ✓ | ✗ | ✗ | ✗ | ✗ |
| | 3x300 | ✗ | ✓ | ✗ | ✗ | ✗ |
|  | 6 | ✓ | ✗ | ✗ | ✗ | ✗ |
| | TMMP 10 | ✗ | ✓ | ✗ | ✗ | ✗ |
| | 15 | ✗ | ✓ | ✓ | ✗ | ✗ |
|  | TMHP 10E | ✗ | ✓ | ✓ | ✗ | ✗ |
| | TMHC 110E | ✓ | ✓ | ✗ | ✗ | ✗ |
|  | 60 | ✓ | ✗ | ✗ | ✗ | ✗ |
| | 80 | ✓ | ✓ | ✗ | ✗ | ✗ |
| | 120 | ✗ | ✓ | ✓ | ✗ | ✗ |
| | TMMA 75H | ✓ | ✓ | ✗ | ✗ | ✗ |
| | 100H | ✗ | ✓ | ✓ | ✗ | ✗ |
| | 75H/SET | ✓ | ✓ | ✗ | ✗ | ✗ |
| | 100H/SET | ✗ | ✓ | ✓ | ✗ | ✗ |
|  | 15 | ✗ | ✗ | ✓ | ✗ | ✗ |
| | TMHP 30 | ✗ | ✗ | ✗ | ✓ | ✗ |
| | 50 | ✗ | ✗ | ✗ | ✗ | ✓ |

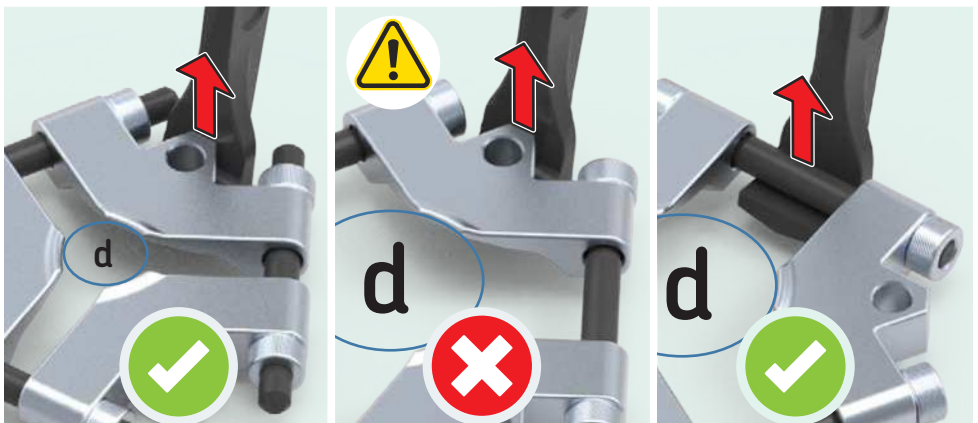
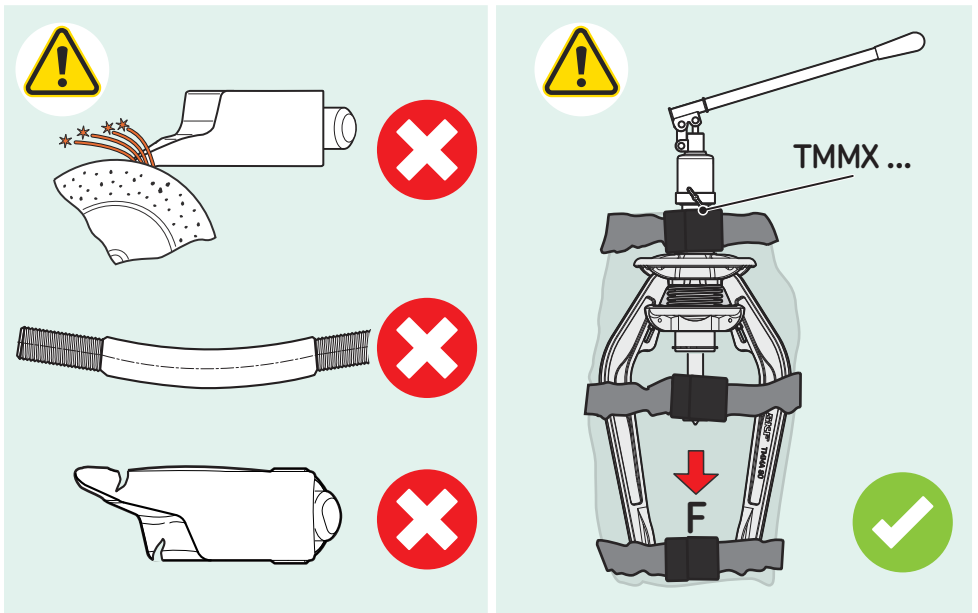
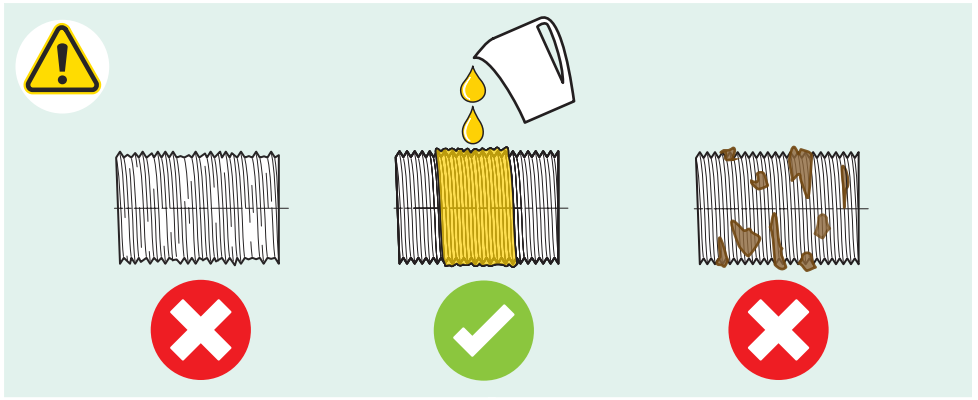

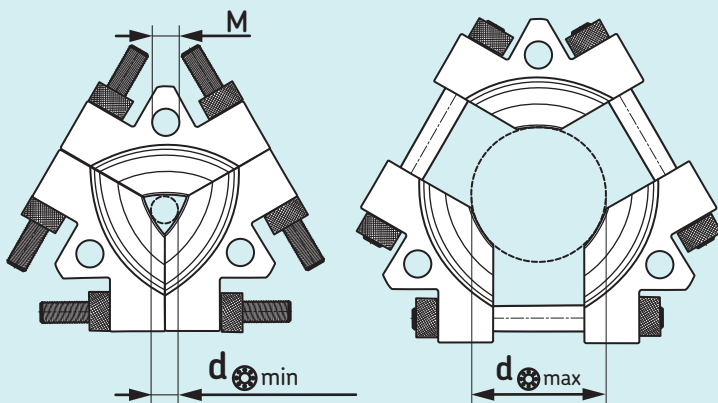

| | d_{min} | | d_{max} | | M |
|----------|------------------|-----|------------------|------|-----------|
| | mm | in | mm | in | mm |
| TMMS 50 | 12 | 0.6 | 50 | 2.0 | - |
| TMMS 100 | 26 | 1.0 | 100 | 3.9 | M16 x 2 |
| TMMS 160 | 50 | 2.0 | 160 | 6.3 | M16 x 2 |
| TMMS 260 | 90 | 3.6 | 260 | 10.2 | M22 x 2,5 |
| TMMS 380 | 140 | 5.6 | 380 | 15.0 | M32 x 2,5 |

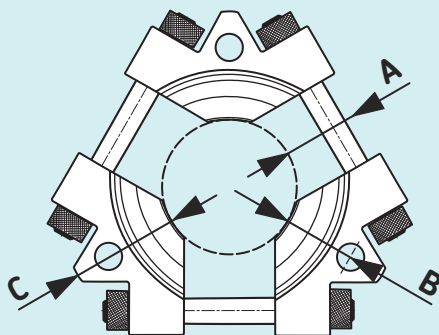

| | A | | B | | C | |
|----------|----------|-----------|----|-----|-----|-----|
| | mm | in | mm | in | mm | in |
| TMMS 50 | 20 - 30 | 0.8 - 1.2 | - | - | 32 | 1.3 |
| TMMS 100 | 36 - 55 | 1.4 - 2.1 | 34 | 1.4 | 60 | 2.4 |
| TMMS 160 | 45 - 73 | 1.8 - 2.9 | 52 | 2.1 | 82 | 3.3 |
| TMMS 260 | 70 - 114 | 2.8 - 4.5 | 81 | 3.2 | 110 | 4.3 |
| TMMS 380 | 81 - 142 | 3.2 - 5.6 | 97 | 3.8 | 138 | 5.4 |

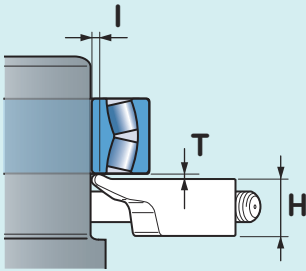

| | H | | T | | l | |
|----------|----|-----|----|------|----|------|
| | mm | in | mm | in | mm | in |
| TMMS 50 | 15 | 0.6 | 2 | 0.08 | 4 | 0.15 |
| TMMS 100 | 25 | 1.0 | 3 | 0.12 | 6 | 0.24 |
| TMMS 160 | 30 | 1.2 | 4 | 0.16 | 8 | 0.32 |
| TMMS 260 | 42 | 1.7 | 5 | 0.20 | 11 | 0.44 |
| TMMS 380 | 58 | 2.3 | 7 | 0.28 | 14 | 0.55 |

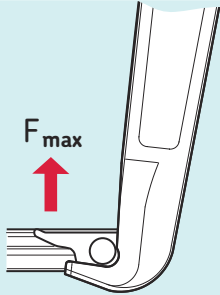

| | F_{max} | |
|----------|-----------|----------|
| | kn | ton (US) |
| TMMS 50 | 80 | 9.0 |
| TMMS 100 | 200 | 23 |
| TMMS 160 | 300 | 34 |
| TMMS 260 | 450 | 51 |
| TMMS 380 | 600 | 68 |



| | m | |
|----------|------|-----|
| | kg | lb |
| TMMS 50 | 0,5 | 1.1 |
| TMMS 100 | 2,6 | 5.7 |
| TMMS 160 | 5,9 | 13 |
| TMMS 260 | 18,4 | 41 |
| TMMS 380 | 50,3 | 110 |

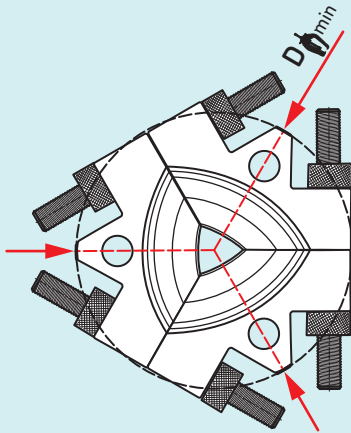

D_{min}

| | D_{min} | |
|----------|-----------|------|
| | mm | in |
| TMMS 50 | 78 | 3.1 |
| TMMS 100 | 150 | 5.9 |
| TMMS 160 | 225 | 8.9 |
| TMMS 260 | 335 | 13.1 |
| TMMS 380 | 455 | 18.0 |

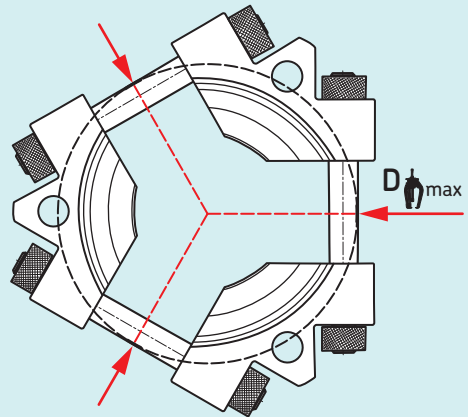

D_{max}

| | D_{max} | |
|----------|-----------|------|
| | mm | in |
| TMMS 50 | 90 | 3.5 |
| TMMS 100 | 170 | 6.8 |
| TMMS 160 | 250 | 9.8 |
| TMMS 260 | 400 | 15.7 |
| TMMS 380 | 540 | 21.4 |

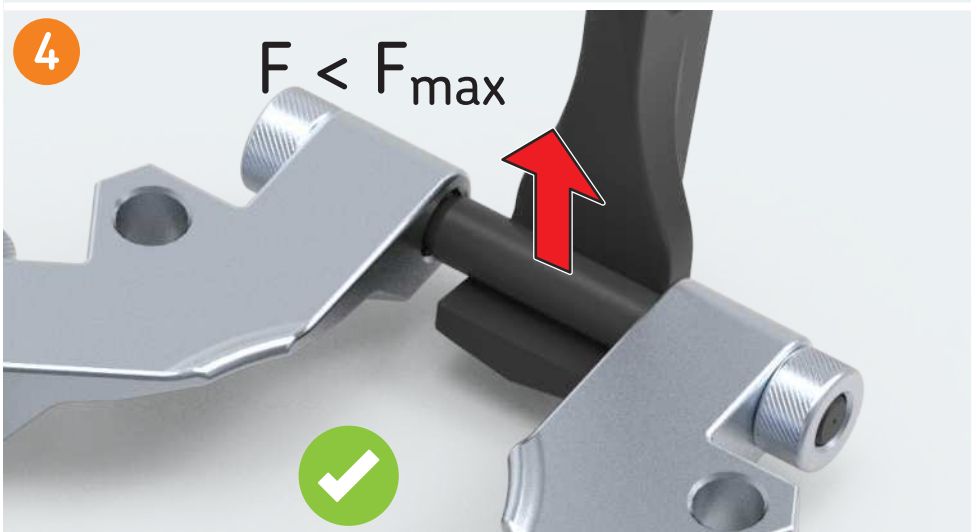
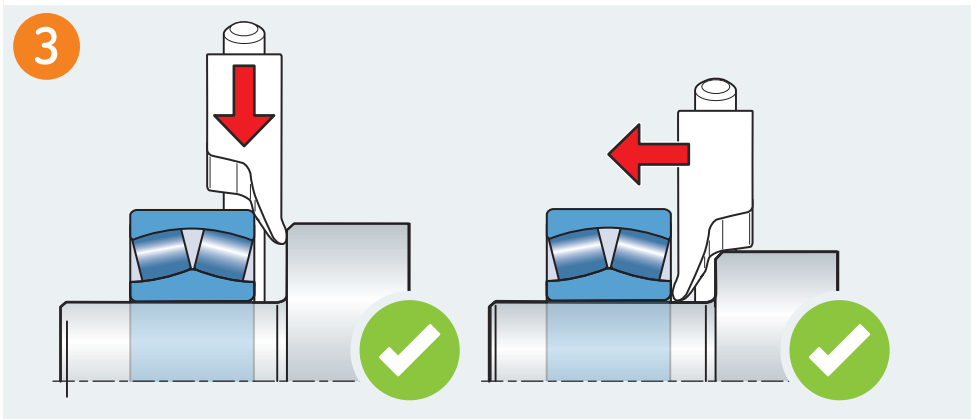
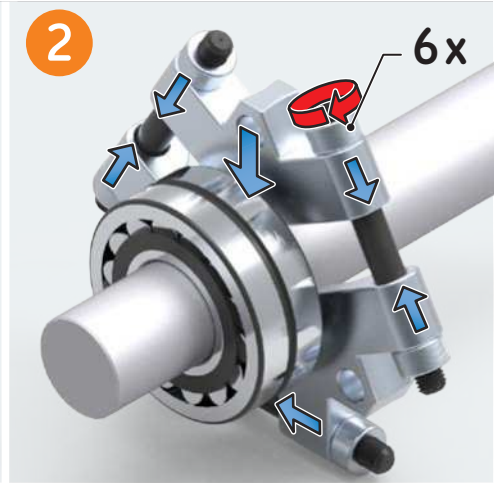
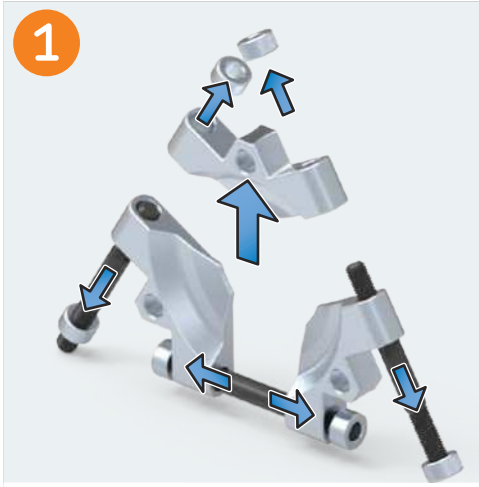

The contents of this publication are the copyright of the publisher and may not be reproduced (even extracts) unless prior written permission is granted. Every care has been taken to ensure the accuracy of the information contained in this publication but no liability can be accepted for any loss or damage whether direct, indirect or consequential arising out of the use of the information contained herein.

Nachdruck, auch auszugsweise, nur mit unserer vorherigen schriftlichen Genehmigung gestattet. Die Angaben in dieser Druckschrift wurden mit größter Sorgfalt auf ihre Richtigkeit hin überprüft. Trotzdem kann keine Haftung für Verluste oder Schäden irgendwelcher Art übernommen werden, die sich mittelbar oder unmittelbar aus der Verwendung der hier enthaltenen Informationen ergeben.

El contenido de esta publicación es propiedad de los editores y no puede reproducirse (incluso parcialmente) sin autorización previa por escrito. Se ha tenido el máximo cuidado para garantizar la exactitud de la información contenida en esta publicación, pero no se acepta ninguna responsabilidad por pérdidas o daños, ya sean directos, indirectos o consecuentes, que se produzcan como resultado del uso de dicha información.

Le contenu de cette publication est soumis au copyright de l'éditeur et sa reproduction, même partielle, est interdite sans autorisation écrite préalable. Le plus grand soin a été apporté à l'exactitude des informations données dans cette publication mais SKF décline toute responsabilité pour les pertes ou dommages directs ou indirects découlant de l'utilisation du contenu du présent document.

La riproduzione, anche parziale, del contenuto di questa pubblicazione è consentita soltanto previa autorizzazione scritta della SKF. Nella stesura è stata dedicata la massima attenzione al fine di assicurare l'accuratezza dei dati, tuttavia non si possono accettare responsabilità per eventuali errori od omissioni, nonché per danni o perdite diretti o indiretti derivanti dall'uso delle informazioni qui contenute.

O conteúdo desta publicação é de direito autoral do editor e não pode ser reproduzido (nem mesmo parcialmente), a não ser com permissão prévia por escrito. Todo cuidado foi tomado para assegurar a precisão das informações contidas nesta publicação, mas nenhuma responsabilidade pode ser aceita por qualquer perda ou dano, seja direto, indireto ou consequente como resultado do uso das informações aqui contidas.

Содержание этой публикации является собственностью издателя и не может быть воспроизведено (даже частично) без предварительного письменного разрешения. Несмотря на то, что были приняты все меры по обеспечению точности информации, содержащейся в настоящем издании, издатель не несёт ответственности за любой ущерб, прямой или косвенный, вытекающий из использования вышеуказанной информации.

本出版物内容的著作权归出版者所有且未经事先书面许可不得被复制(甚至引用)。我们已采取了一切注意措施以确定本出版物包含的信息准确无误,但我们不对因使用此等信息而产生的任何损失或损害承担任何责任,不论此等责任是直接、间接或附随性的。



skf.com • skf.com/mapro

® SKF is a registered trademark of the SKF Group.

© SKF Group 2024

MP5145 · 2024/09