

SKF TMMP 6/10/15

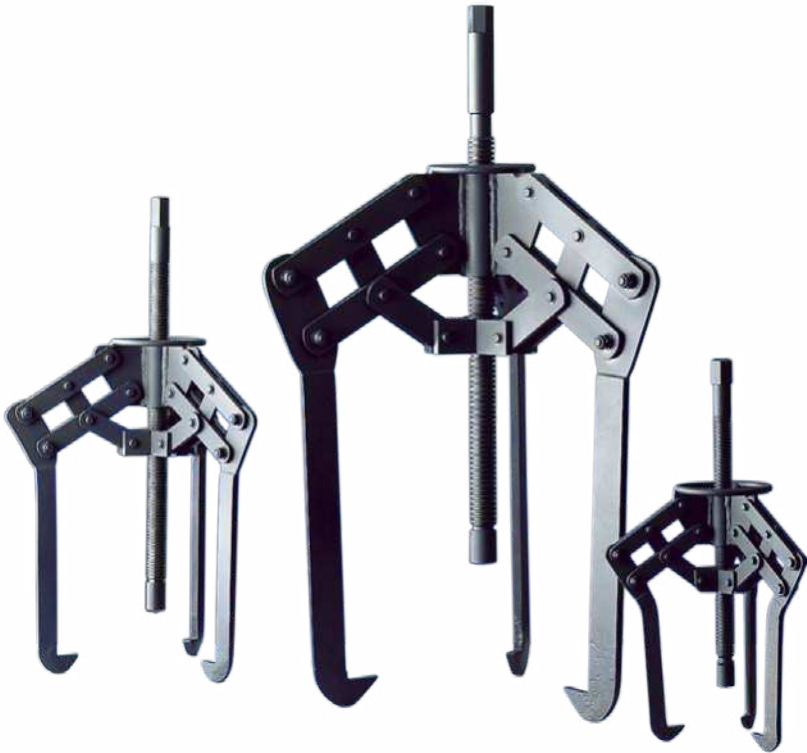

Table of contents

Safety recommendations3

1. Application4

2. Description.....4

3. Definition of parts and dimensions5

4. Technical data6

5. Replacement parts7

Original instructions



Safety recommendations

- The equipment should only be operated by trained personnel.
- Always follow the operating instructions.
- Check the puller and all accessories carefully before use. Never use even slightly damaged components.
- Make sure the force rating of the puller (F) exceeds calculated maximum withdrawal force.
- Do not exceed the maximum torque (T) when applying force on a mechanical spindle.
- Always prevent the workpiece/tool from being projected upon sudden release of pressure (e.g. by use of retaining nut).
- Ensure that the puller legs are properly secured around the workpiece. Each claw must be fully engaged.
- Ensure that the separators are properly secured behind the workpiece.
- Make sure the force is equally distributed in all arms.
- Never use the equipment above the stated maximum force.
- Use protective goggles.
- Cover the work with a protective blanket or shield while force is being applied.
- Never modify the unit.
- Use original parts only.
- In case of any uncertainties in regard to the use of the puller, contact SKF.



1. Application

The TMMP 6, TMMP 10 and TMMP 15 are suitable for dismantling medium to large size bearings and other machinery components.

A unique pantograph system for adjustment of the width of the grip prevents misalignment during operation, thereby reducing the risk of damage to the shaft or the bearings.

The maximum withdrawal force ranges from 6 metric tonnes (*13 500 lbf*) for the TMMP 6 to 15 metric tonnes (*33 700 lbf*) for the TMMP 15.

2. Description

The pullers are all made of blackened, high-quality steel and are equipped with three arms. No pre-setting of the width of grip is required. The puller will open fully when the boss holding the arms is pushed forward, and close to grip the bearing when the boss is pulled backward. This feature makes the TMMP 6, TMMP 10 and TMMP 15 fast and practical tools to work with.

3. Definition of parts and dimensions

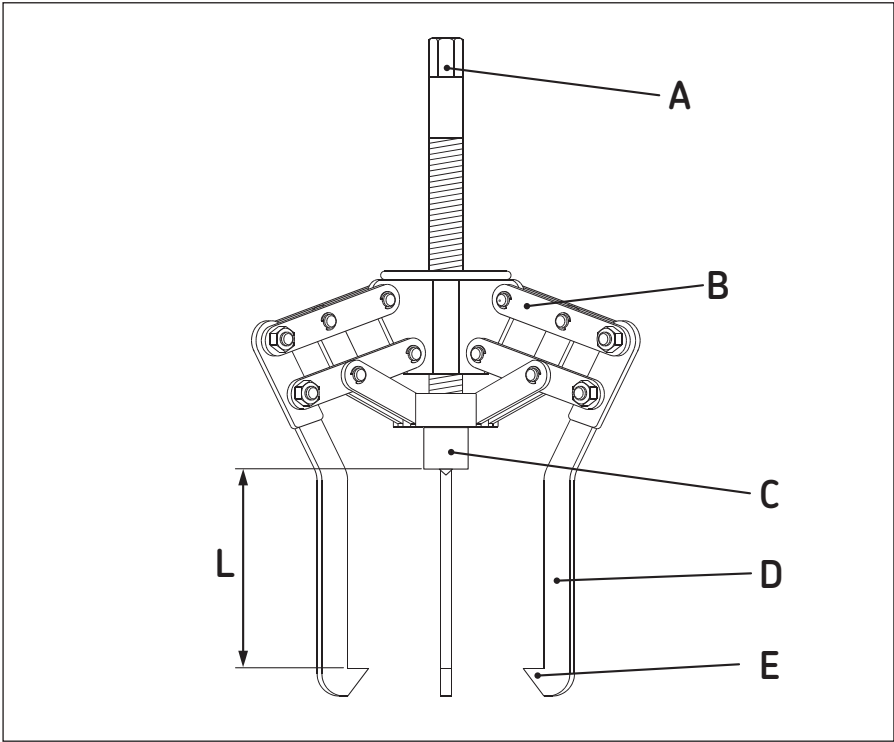

A	Spindle hexagon head
B	Boss
C	Spindle
D	Arm
E	Claw
L	Effective arm length

4. Technical data

Designation	TMMP 6	TMMP 10	TMMP 15
No. of arms	3	3	3
Width of grip	50-127 mm (2.0-5.0 in)	100-223 mm (3.9-8.7 in)	140-326 mm (5.5-12.8 in)
Effective arm length (L)	120 mm (4.7 in)	207 mm (8.2 in)	340 mm (13.4 in)
Maximum withdrawal force (F)	60 kN (6.7 US ton)	100 kN (11.2 US ton)	150 kN (17 US ton)
Maximum torque (T)	175 Nm (130 lbf ft)	340 Nm (250 lbf ft)	700 Nm (515 lbf ft)
Weight	4.0 kg (8.8 lb)	8.5 kg (19.0 lb)	21.5 kg (47.4 lb)

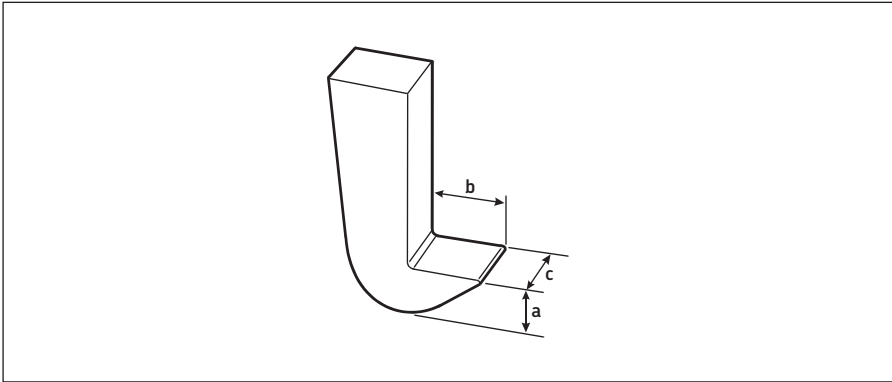

Designation	TMMP 6	TMMP 10	TMMP 15
Claw height (a)	15 mm (0.59 in)	20 mm (0.78 in)	30 mm (1.18 in)
Claw length (b)	19mm (0.75 in)	26 mm (1.02 in)	37 mm (1.46 in)
Claw width (c)	8 mm (0.31 in)	10 mm (0.39 in)	12 mm (0.47 in)
Spindle hexagonal head (AF)	22 mm	21 mm	28 mm

5. Replacement parts

Ref.	Designation	Description	TMMP 6	TMMP 10	TMMP 15
A	TMMP ...-5	Spindle with centre nib			
B	TMMP ...-1	Arm length (L)	120 mm* (4.7 in)	207 mm* (8.1 in)	260 mm (10.2 in)
B	TMMP ...-2	Arm length (L)	220 mm (8.7 in)	350 mm (13.8 in)	340 mm* (13.4 in)
B	TMMP ...-3	Arm length (L)	370 mm (14.6 in)	460 mm (18.1 in)	435 mm (17.1 in)
B	TMMP ...-4	Arm length (L)	470 mm (18.5 in)	710 mm (28.0 in)	685 mm (27.0 in)

* Standard arm. Other arms available as optional equipment.

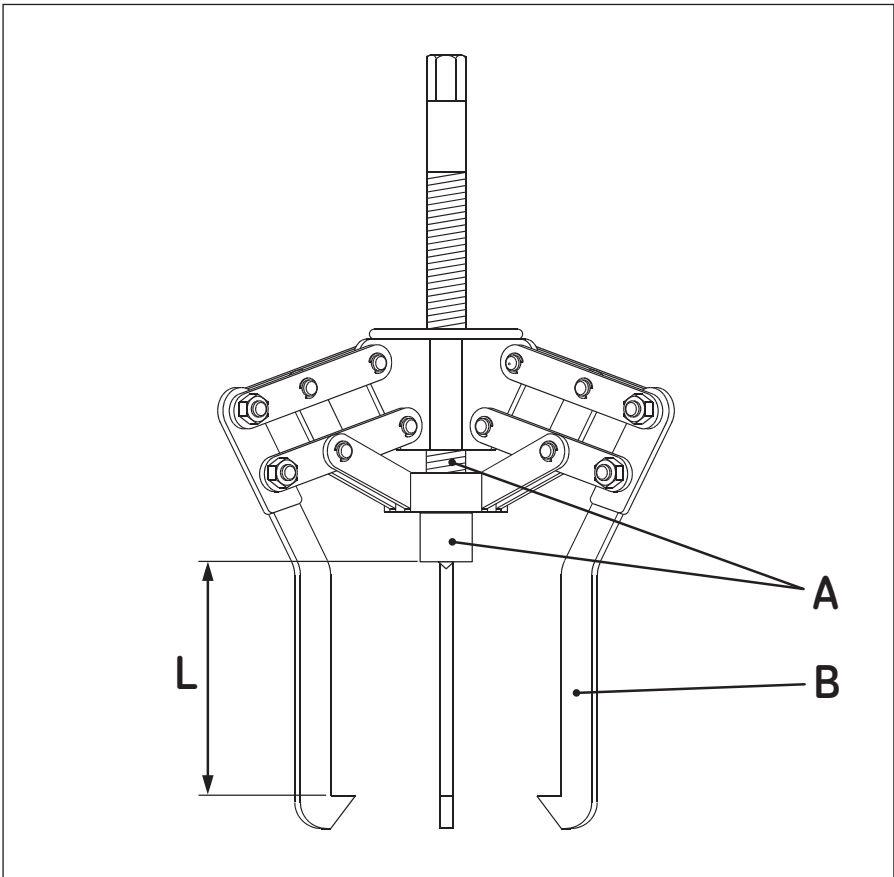

skf.com | mapro.skf.com | skf.com/mount

© SKF is a registered trademark of the SKF Group.

© SKF Group 2022

The contents of this publication are the copyright of the publisher and may not be reproduced (even extracts) unless prior written permission is granted. Every care has been taken to ensure the accuracy of the information contained in this publication but no liability can be accepted for any loss or damage whether direct, indirect or consequential arising out of the use of the information contained herein.

MP584 EN · 2022/07